

The SM1-PH is a high quality, 12V-24VDC powered, pre-amplified, pin hole style microphone designed to connect to DRVs, I/P cameras, etc. Note- the audio output of the SM1-PH is switch selectable “line level” (0db) or “microphone level” (-30db).

Microphone

Plug the ML1-PH microphone into the “mic in” jack of the SM1-PA pre-amplifier. Do not mount the ML1-PH microphone near air conditioning vents, light fixtures or electrical equipment.

The ML1-PH microphone should be placed as close as possible to the subject of interest. The ML1-PH microphone is useable in the range of 3-25 feet but is dependent on the level of background noise in the area. Experimentation in the environment will determine what distances work best.

Cable Run

Run a 22 gauge, stranded, two conductor shielded cable between the SM1-PH pre-amplifier and the monitoring device. Keep the cable run distance under 1,000 feet and away from AC power sources, light fixtures and electrical equipment. Connect power to the + terminal, the audio signal to the “audio” terminal and ground to the – terminal. The Ground of the power and audio signal must share a common ground for proper operation. See *Figure 1 for connection diagram*.

Mounting

The SM1-PH is designed to be mounted in a ceiling tile or wall. See figure 2.

Adjusting the SM1-PH Gain

The SM1-PH output level is set by selecting the desired volume range and adjusting the gain control.

The “Volume Range” switch should be set to the “LO” position when using the SM1-PH with I/P cameras that utilize “microphone inputs” also known as “Mic. Level” inputs. This sets the maximum gain of the SM1-PH’s pre-amp to x14. The switch should be placed in the “HI” position when using I/P cameras with “Line level” inputs of DVRs and I/P cameras. This sets the maximum gain of the SM1-PH’s pre-amp to x196.

The SM1-PH is shipped with the gain set at midrange. If the sound at the “head end” is distorted, rotate the control towards the – mark (counter-clockwise). If the volume at the “head end” is too low, rotate the control towards the + mark (clockwise).

Setting the SM1-PH Hi-Cut/Lo-Cut Switches

The normal frequency response of the SM1-PH microphone is 500-13Khz. When both switched “On”, The “HI Cut” and “Lo Cut” filters set the SM1-PH’s frequency response to 900-6Khz. Enabling one or both of the filters is useful when background noise needs to be further reduced and intelligibility of speech emphasized. We recommend experimenting with the jumper settings to achieve the best acoustic result for your application.

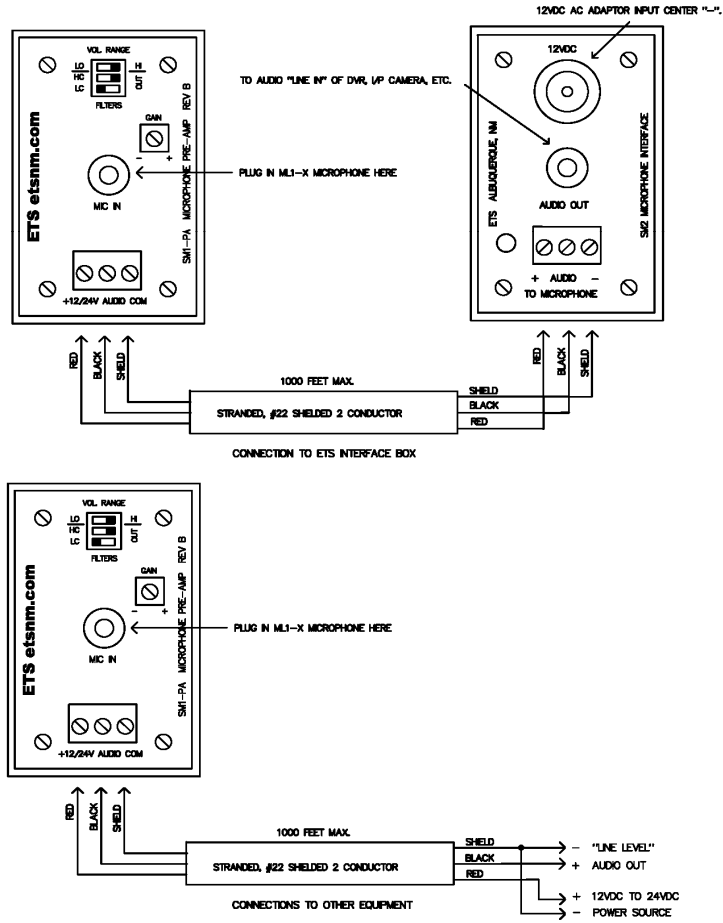

Figure 1

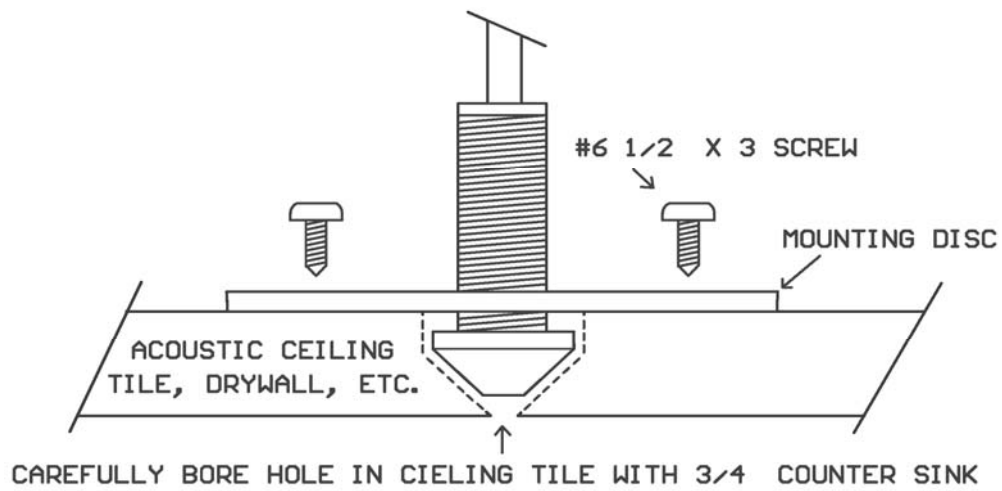

Figure 2

Caution

It may be against the law to install this microphone kit in certain environments. It may also be against the law to record conversations of the person(s) being monitored without their knowledge. It is the responsibility of the installation company and end-user to determine if the application of this product is legal. These laws vary from state to state. If you are not informed on these matters, consult a qualified attorney or contact the appropriate state agency. A sticker is provided with this kit for the applications where notification must be posted.

Warranty

All ETS products carry a one year parts and labor warranty. This warranty does not cover damages as a result of misuse, improper handling of the unit or exposure to extreme temperatures or moisture. At its discretion, ETS reserves the right to repair or replace this unit under the conditions of the warranty. If you experience problems with your equipment call ETS at: 505-888-3923 to obtain a return authorization number. Equipment requiring repair beyond the warranty period or units that have been damaged or are not covered under the warranty can be repaired by ETS for a minimal cost under most conditions.

Made in the USA
by
ETS Inc.