

The SM5-EA is a single channel, one way pre-amplified microphone “listen in” surveillance kit designed to be used with Power Over Ethernet IP cameras. It provides a convenient way of supplying power to the SM1 by tapping power off the camera’s Ethernet connection. The SMEA-1 interface features installer friendly termination of the cable runs and a standard RCA or 3.5mm audio output connector. The output of the SMEA-1 can be used on microphone or line level inputs of PoE IP camera. The SMEA-1 can be connected to a “microphone” or “line” level input of a PoE IP camera.

### **SM1 Microphone Placement**

Locate the SM1 microphone as close as possible to the area of interest in the space to be monitored. If a large area is to be monitored, locate the SM1 in the middle of the room. Do not mount the microphone near air conditioning vents, light fixtures or electrical equipment. The SM1 should be placed as close as possible to the subject(s) to be monitored. The SM1 is still useable at distances of up to 25 feet but is dependent on the level of background noise in the area. Experimentation in the environment will determine what distances work best.

### **SMEA-1 location and power**

The SMEA-1 interface box is designed to be located any place along the IP camera CAT5 cable run. It must be located in between the IP camera and the router or switcher as shown in figure 1.

#### **NOTES-**

1. The IP camera **MUST** be connected or the SMEA-1 will not power up.
2. The SMEA-1 will not work with non-PoE IP cameras.

### **Cable Run**

Run a 22 gauge, stranded, two conductor shielded cable between the SMEA-1 interface and the SM1 microphone. Keep the cable run distance under 1,000 feet and away from AC power sources, light fixtures and electrical equipment. See *Figure 1 for connection diagram.*

### **Mounting**

The SM1 can be surface or flush mounted on ceilings or walls. For flush mounting, cut a 2 ¼” by 2 ¾” hole in the wall or ceiling tile to allow room for the circuit board and mount the SM1 to the surface with screws.

### **Adjusting the SM1 “gain” and SMEA-1 “level” controls**

If the SM5-EA will be plugged into a “microphone level” input of an IP camera, set the SM1 gain slightly clockwise (or 1/8 of a full turn) from full counter-clockwise. Then use the “level control” on the SMEA-1 to set a volume that produces an acceptable audio level at the head end.

If the SM5-EA will be used with a “line level” input, turn the gain control of the SM1 to 3/4 full clockwise and adjust the level control on the SMEA-1 to produce the clearest audio level at the head end.

### **Setting the SM1 Jumpers**

The “Volume Range” jumper should be set to the “LO” position when using the SM1 with IP cameras that utilize “microphone inputs” also known as “Mic. Level” inputs. This sets the maximum gain of the SM1’s pre-amp to x11. The jumper should be placed in the “HI” position when using IP cameras with “Line level” inputs of DVRs and IP cameras. This sets the maximum gain of the SM1’s pre-amp to x121.

The normal frequency response of the SM1 microphone is 500-13Khz. When both jumpered “in”, The “HI Cut” and “Lo Cut” filters set the SM1’s frequency response to 900-3.9Khz . Enabling one or both of the filters is useful when background noise needs to be reduced and intelligibility of speech emphasized. We recommend experimenting with the jumper settings to achieve the best acoustic result for your application (s).

**SMEA-1 Mode switch:** The SMEA-1 supports Both Modes A and B of IEEE802.3af POE. The SMEA-1 is pre-configured for the most common use of the “end point” POE IEEE802.3af standard (mode A). If the power LED does not illuminate in this position, try the mode B position (mid span).

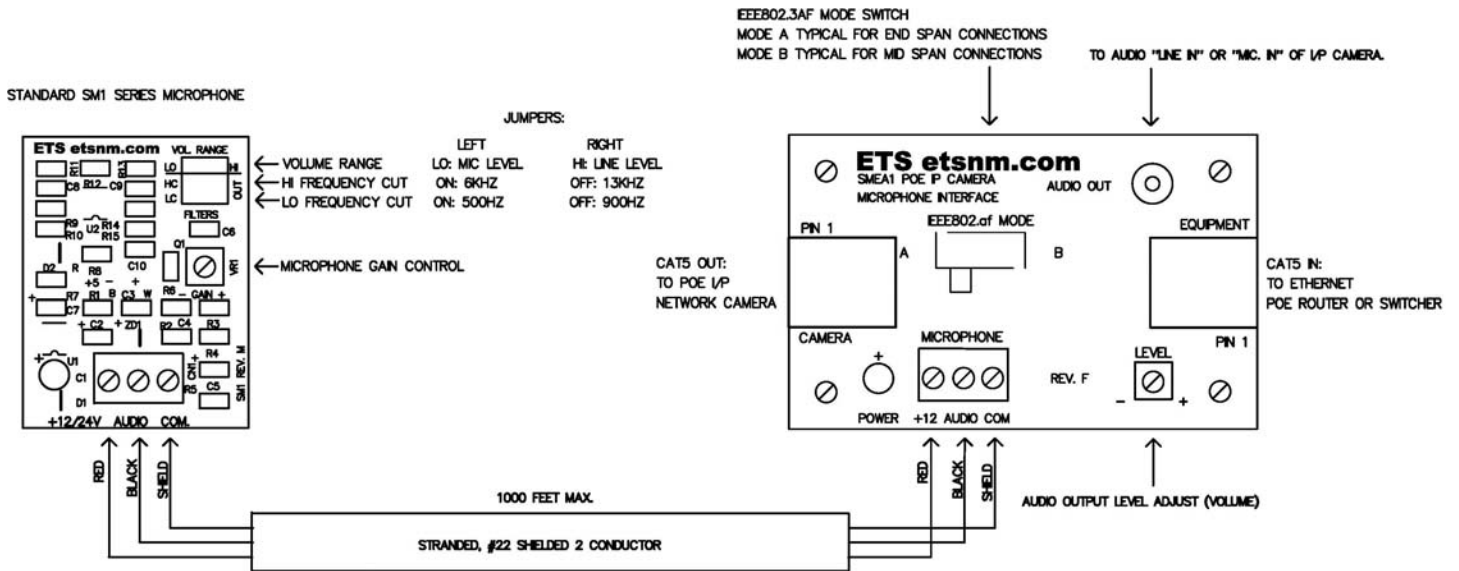

Figure 1.

### Caution

It may be against the law to install this microphone kit in certain environments. It may also be against the law to record conversations of the person(s) being monitored without their knowledge. It is the responsibility of the installation company and end-user to determine if the application of this product is legal. These laws vary from state to state. If you are not informed on these matters, consult a qualified attorney or contact the appropriate state agency. A sticker is provided with this kit for the applications where notification must be posted.

### Warranty

All ETS products carry a one year parts and labor warranty. This warranty does not cover damages as a result of misuse, improper handling of the unit or exposure to extreme temperatures or moisture. At its discretion, ETS reserves the right to repair or replace this unit under the conditions of the warranty. If you experience problems with your equipment call ETS at: 505-888-3923 to obtain a return authorization number. Equipment requiring repair beyond the warranty period or units that have been damaged or are not covered under the warranty can be repaired by ETS for a minimal cost under most conditions.

Made in the USA  
by  
**ETS Inc.**