



Electronic Technical Services Inc.
 211 Conchas SE
 Albuquerque, NM 87123
 PH 505-888-3923 FAX 505-888-3926
 Website: www.etsnm.com

Sound Surveillance™

ML1-HS Panel Mount, Weather Proof, Tamper Resistant, Omni-directional Microphone

Description

The ML1-HS is a high performance, low, cost omni-directional, IP54 rated electret microphone for use with IP cameras accepting **microphone level input** signals (PC compatible input). The attached cord is 6' long and comes standard with a stereo 3.5mm connector on one end. Add -FL to the P/N for a flying lead output for connections to cameras with terminal blocks.

For use with IP cameras accepting microphone level inputs (the camera supplies power to ECM cartridge)

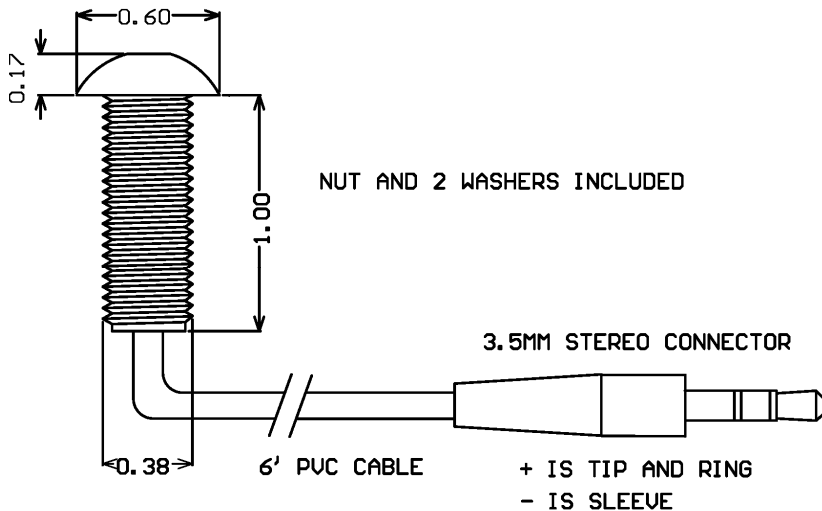

ML1-HS Specifications

- Omni-directional pattern
- Max SPL 120db
- Frequency response: 40-17khz
- Sensitivity -44db
- -40db output (mic level)
- 2-10Vdc operation
- 2-5k Ohm load resistance
- S/N 60db
- 6' standard cable length
- 3.5mm stereo connector
- Anodized aluminum housing
- IP54 rated
- Operating temperature -40 to 85C
- Weight: 0.025 kg

Caution

It is the responsibility of the installation company and end user to install this audio surveillance equipment in compliance with state and federal privacy laws. If you are unfamiliar with these laws, consult a qualified attorney.

Warranty 1 year parts and labor,

Made in USA

Includes

- ML1-HS microphone.
- Warning label.
- Mounting locknut and 2 washers.

Options:

- Cable lengths of up to 25' are available. Add -XX to P/N where XX = number of feet
- Add -FL to P/N for flying lead output
- Add -LN to P/N for higher performance capsule