

ETS Inc. STW4 Two way Monitoring Station Instructions

The STW4 is a 4 zone 2-way Audio surveillance monitoring station for use with all ETS STW1 series speaker / microphones. It can be used independently for monitoring live audio or with audio recorders or DVRs for recording and playback.

STW1 Mounting

Locate the STW1 Microphone/Speaker near the area of interest. Do not mount the STW1 near air conditioning vents, light fixtures or electrical equipment. Try to keep the distance between the STW1 and the STW4 under 1,000 feet.

Cable Run

For the Microphone, run a 22 gauge, 2 conductor shielded cable (500 feet maximum length) between the STW1 and the STW4 base station. Keep the cable away from AC power sources, light fixtures and electrical equipment.

For the Speaker, run a 22 gauge, 2 conductor shielded cable (500 feet maximum length) between the STW1 and the STW4. For the optional Call Switch, a 22 gauge, 2 conductor cable can be used. This is a contact closure type of connection so it doesn't matter which side goes where. Do not use a single multiconductor cable for the cables or crosstalk may occur.

Setting the STW1 Microphone Gain

The STW1 output level is set by selecting the desired volume range and adjusting the gain control.

The "Volume Range" jumper should be set to the "LO" position when using the STW1 with IP cameras that utilize "microphone inputs" also know as "Mic. Level" inputs. This sets the maximum gain of the STW1's pre-amp to x14. The jumper should be placed in the "HI" position when using IP cameras with "Line level" inputs of DVRs and IP cameras. This sets the maximum gain of the STW1's pre-amp to x196.

The STW1 is shipped with the gain set at midrange. If the sound at the "head end" is distorted, rotate the control towards the – mark (counter-clockwise). If the volume at the "head end" is too low, rotate the control towards the + mark (clockwise).

Setting the STW1 Microphone Hi-Cut/Lo-Cut Jumpers

The normal frequency response of the STW1 microphone is 500-13Khz. When both jumpered "in", The "HI Cut" and "Lo Cut" filters set the STW1's frequency response to 900-6Khz . Enabling one or both of the filters is useful when background noise needs to be further reduced and intelligibility of speech emphasized. We recommend experimenting with the jumper settings to achieve the best acoustic result for your application.

STW4 Base Station Controls

After connections have been made, apply power to the unit and the system is ready to use. You should hear all 4 STW1s audio on the STW4 base station Speaker. Adjust the main "Volume" knob to a comfortable level. You can set individual channel volumes by the pot under the channel LED.

Sending a message to the STW1s

Select the channels you wish to send a message to (verify that your chosen channel's green LED lights are lit).

Then press and hold the "Push To Talk" button on the base station. The yellow LED light indicates that the base station microphone is sending audio to the selected STW1s.

Speak in the direction of the microphone opening. Release the "Push To Talk" button when you have finished your message. The yellow LED will go out.

If necessary, you can adjust the remote Speaker volume by turning the "Remote Volume" knob clockwise for louder sound and counter clockwise for softer sound.

Audio connection to a recording device

Connect the "Audio Out" jack to the recording device's "Audio In", using the supplied RCA cables. Connect the "Audio In" jack to the recording device's "Audio Out." Press and hold the Channel 1 button until the red "Recorder In" light comes on (about 2 seconds.)

Headphones

Plug headphones into the "Headphone" jack on the front panel of the STW4. Audio will be cut out on the base station speaker.

Optional Call Switch

If you have the "Call Switch" option, simply press the button on the STW1 to start a 1 second tone to the STW4. The called STW1 channel will flash until you press any channel button to acknowledge. To hear that channel's audio, press the button that corresponds to the flashing channel.

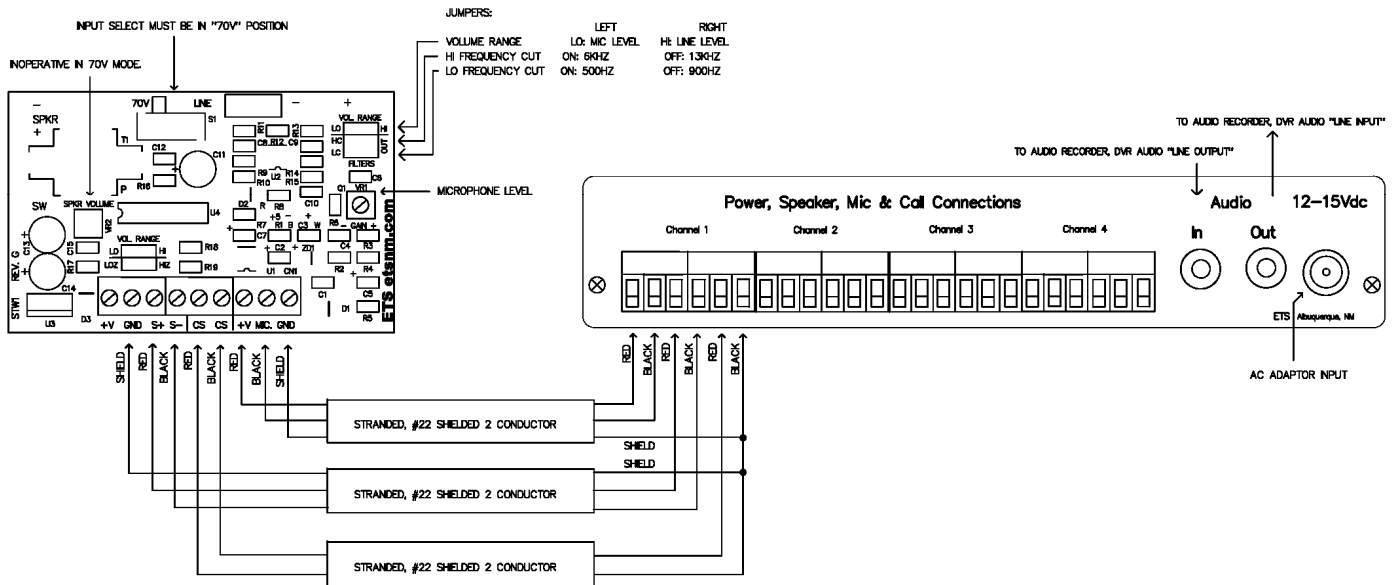

Caution

It may be against the law to install this microphone kit in certain environments. It may also be against the law to record conversations of the person(s) being monitored without their knowledge. It is the responsibility of the installation company and end-user to determine if the application of this product is legal. These laws vary from state to state. If you are not informed on these matters, consult a qualified attorney or contact the appropriate state agency. A sticker is provided with this kit for the applications where notification must be posted.

Warranty

All ETS products carry a one year parts and labor warranty. This warranty does not cover damages as a result of misuse, improper handling of the unit or exposure to extreme temperatures or moisture. At its discretion, ETS reserves the right to repair or replace this unit under the conditions of the warranty. If you experience problems with your equipment call ETS at: 505-888-3923 to obtain a return authorization number. Equipment requiring repair beyond the warranty period or units that have been damaged or are not covered under the warranty can be repaired by ETS for a minimal cost under most conditions.

Made in the USA

by

ETS Inc.