

# ETS Inc.

## SS8-RC RS232 Controllable Speaker Switcher / Driver Instructions

---

The SS8-RC is a RS232 controllable speaker switcher / driver for use with commonly available 70v speakers or ETS 70v speakers. The SS8-RC is primarily designed to be used in conjunction with DVRs / video gateways in one way (or two-way: using the companion SM8-RC speaker switcher) to expand versatility in audio zone handling. **Note-** the DVR manufacturer must write custom software to “talk” to the –RC series switchers via an available RS232 port on the DVR using a simple ASCII protocol described later in this document.

Note-If your application requires more than 8 audio zones, you must add (loop or cascade) additional SS8-RCs for 8 more zones and up to a maximum of 32 zones total (4 SS8-RCs). Each SS8-RC is assigned an ID number for its range of zones as described later in this document.

### Front panel controls and indicators

When powered up, the SS8-RC is in remote control mode (the front switches do not work.)

If you want to control the switcher manually, press and hold the Zone 1 button until the “Recorder” indicator light goes out. You can now select and deselect Zones by pressing their respective channel buttons. You can also set the volume of a zone by adjusting the corresponding Level control.

To go back to RS-232 control mode, press and hold the Zone 1 until the “Recorder” light illuminates.

### Setting the zone range ( ID ) for looped SS8-RCs

Unplug the SS8-RC from its AC power Source. Press and HOLD DOWN the corresponding zone number which translates to ID channel number. CH1=ID1....CH4=ID4. Power up the SS8-RC until the corresponding channel light illuminates. Then release the switch and the CH lamp will extinguish shortly thereafter.

ID 1= zones 1-8      ID 2= zones 9-16      ID 3= zones 17-24      ID 3= zones 25-32

Note-On a power down / up cycle of the SS8-RC, the ID of the unit will be shown on the corresponding zone lamp (1-4) for 2 seconds.

### Rear panel connections

**PWR:** The SS8/16-RC uses a 16.5 vac 40va transformer. *Note- the SS8-RC and SM8-RC use different types of AC adapters.*

**Audio In** Connector: Connect this to the Audio output of the remote monitoring equipment.

**Audio Out** Connector: When using 16 zones of audio, connect the Audio output of the SS8-RC to the input of the SS16-RC using the supplied RCA patch cable.

**RS-232** Connectors: This is a looping RS-232 input and output. You only need one RS-232 port on your remote monitoring equipment to control up to 4 SS8/16-RC and SM8/16-RC devices. Plug the RS-232 DB9/3.5mm cable into either RS-232 jack on the SS8-RC. Connect the other end of this cable to your remote monitoring equipment. Plug the supplied 3.5mm/3.5mm patch cord into the other jack if using a 16 zone system (see connection diagram).

**Speaker outputs.** Use a single pair shielded #22 wire for speaker cable runs. Connect the Shield of the supplied cable to the S terminal. Connect the red wire to the + terminal. Connect the black wire to the – terminal. If using ETS speakers, connect the other end of this cable to the speakers in the exact same way. **Speakers must be 70V line types.**

## ETS microphone speaker switcher command protocol version 2.0

**Note-** all selected channel settings are lost during a power outage of an SS8-RC. The –RC series switchers are also, RS232, listen only devices and currently do not communicate back any information to the host controller. Therefore, it is recommended that the host control software periodically update the switchers via RS232 with the current settings as a precaution so as to not lose track of channel settings during a power loss.

## Command format

- All commands received must be RS232, 2400 Baud, 8N1 (8 data bits, No parity and 1 stop bit).
- All commands must be ASCII characters and all letters must be upper case.
- Each command string must be immediately followed with a <CR> (0D hex) character to mark the end of transmission. DO NOT add a <LF> (0A hex) after <CR>.
- All single digit channel addresses must have an ASCII 0 zero preceding them. 00 is not a valid channel number.  
Example: 01,02,03
- All channels addressed in the “multi channel format” described below must have commas as separators between channel numbers. 01-99 is the valid range. Example: **MI,01,50,99<CR>**
- Commands may be combined with the asterisk \* (2A hex) command separator character to form a single command transmission string as in the following format Example: **MI01\*SO01,99\*MI02\*BO16,32<CR>**.
- Each command must be 5 characters minimum in length including the <CR> character. Single combined command strings cannot exceed 48 chars total.
- Because there is no report back of switcher channel status to the host computer from the switchers, it is highly recommended that a global command such as BN<CR> preface all switching commands. This way you will always know all channels are off before turning any channels on. Other approaches are valid, but require keeping track of enabled channels in the host software.

### MICROPHONES (M=Microphone)

#### Function Command

MICROPHONE “IN” **MIxx<CR>** (xx=01-99) 01=1, 02=2, etc. Multi channel format: **MI01,99 <CR>**

MICROPHONE “OUT” **MOxx<CR>** (xx=01-99) 01=1, 02=2, etc. Multi channel format: **MO01,99<CR>**

MICROPHONE “ALL” **MA<CR>**

MICROPHONE “NONE” **MN<CR>**

---

### SPEAKERS (S=Speaker)

#### Function Command

SPEAKER “IN” **SIxx<CR>** (xx=01-99) 01=1, 02=2, etc. Multi channel format: **SI01,99<CR>**

SPEAKER “OUT” **SOxx<CR>** (xx=01-99) 01=1, 02=2, etc. Multi channel format: **SO01,099<CR>**

SPEAKER “ALL” **SA<CR>**

SPEAKER “NONE” **SN<CR>**

---

### BOTH MICROPHONES and SPEAKERS (B=both)

#### Function Command

MIC AND SPEAKER “IN” **BIxx<CR>** (xx=01-99) 01=1, 02=2, etc. Multi channel format: **BI01,99<CR>**

MIC AND SPEAKER “OUT” **BOxx<CR>** (xx=01-99) 01=1, 02=2, etc. Multi channel format: **BO01,99<CR>**

MIC AND SPEAKER “ALL” **BA<CR>**

MIC AND SPEAKER “NONE” **BN<CR>**

## Warranty

All **ETS** products carry a one year parts and labor warranty. This warranty does not cover damages as a result of misuse, improper handling of the unit or exposure to extreme temperatures or moisture. At its discretion, **ETS** reserves the right to repair or replace this unit under the conditions of the warranty. If you experience problems with your equipment call **ETS** at: 505-888-3923 to obtain a return authorization number. Equipment requiring repair beyond the warranty period or units that have been damaged or are not covered under the warranty can be repaired by **ETS** for a minimal cost under most conditions.

**Made in the USA by ETS Inc.**

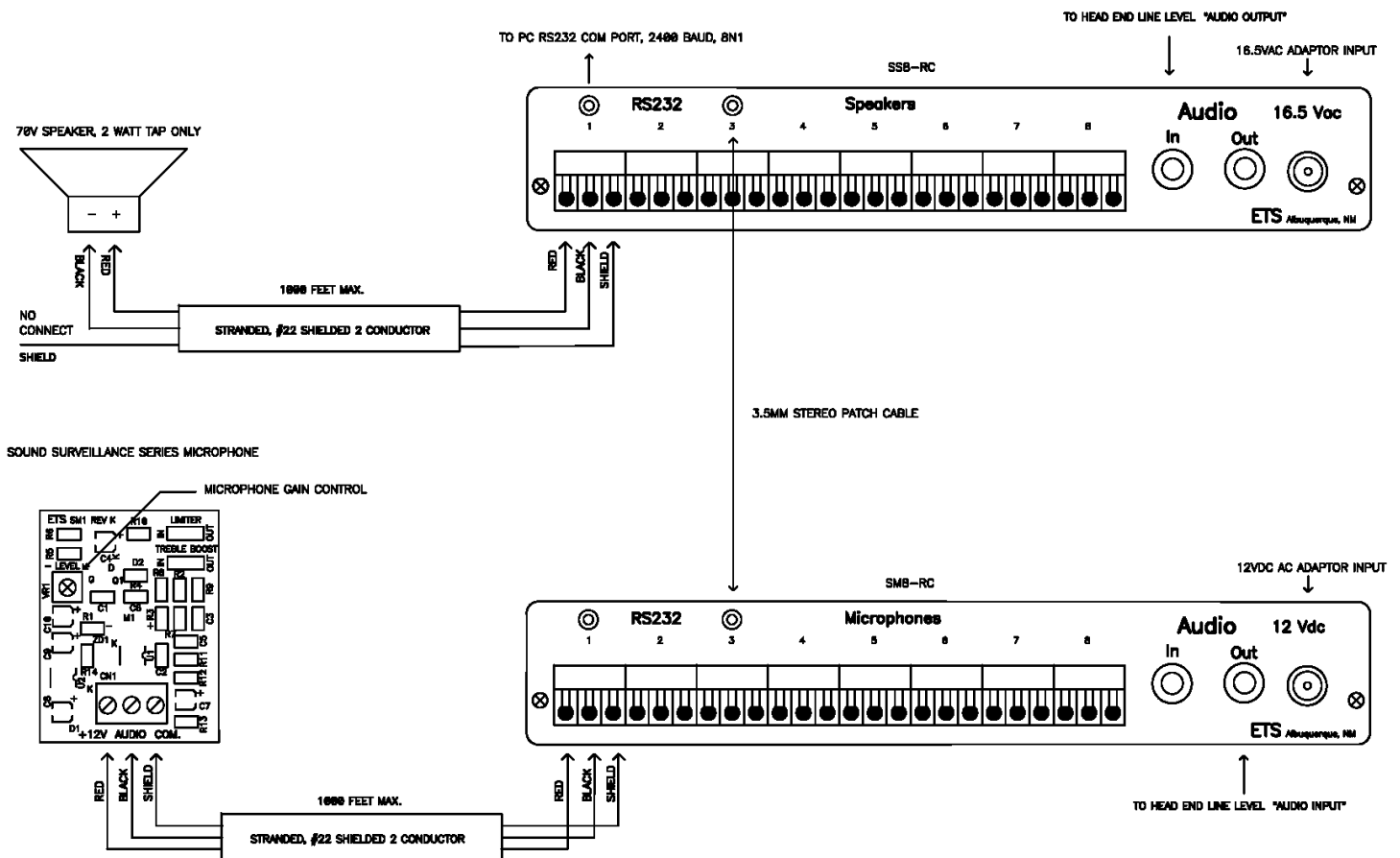
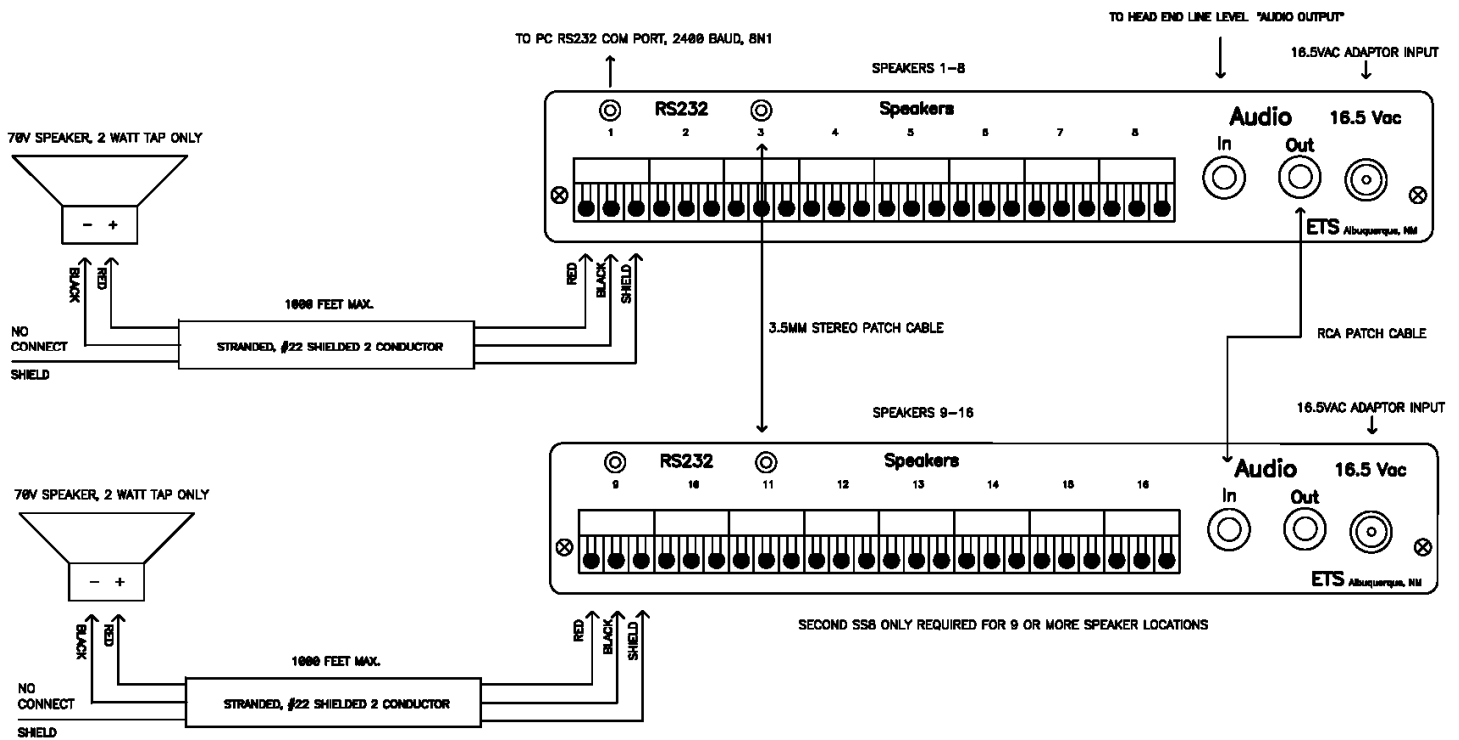

FIGURE 2. 8 CHANNEL TWO-WAY CONFIGURATION