



RDA-3 Wiegand card reader DA Instructions

The RDA-3 distributes the data from one Wiegand reader to up to three data access control panels. Monitors the LED outputs of the data panels and outputs an LED "access granted" in the case of any panel valid card read or a "access denied" if all three data panels report non-valid card reads.

Power input / output

The RDA-3 accepts 12vdc in and consumes 20ma of power. It has a +12v or +5v output that can be used to power up the reader. The RDA-3 can supply up to 500ma 5v power to the reader. If the Wiegand reader requires 12vdc power, select the 12v position of the reader power jumper. If the reader requires 5vdc power, select the 5v position.

Data outputs

Whatever data comes out of the Wiegand reader will appear at the terminals of the D0 and D1 terminals of the access control panel outputs. Connect these outputs to the access control panel reader inputs. See figure 1. Note- no card read data is stored in the RDA-3.

LED signals

All LED inputs are normally high. The inputs to the RDA-3 from the access control panels can be 5v or 12v. When a valid card read is detected by any of the 3 "green LED" inputs going low, the RDA-3 will send a "green LED" signal to the Wiegand reader green LED terminal (logic low). If an invalid card read is detected by any or all of the 3 "red LED" inputs going low, the RDA-3 will send a "red LED" signal to the Wiegand reader red LED terminal (logic low). See figure 1 For connections.

Cabling

Run a #22 6 conductor shielded from the Wiegand reader to the RDA-3. Run up to 3 each #22 6 conductor shielded cables from the RDA-3 to each access control panel. The shield can be used as a common.

Warranty

All ETS products carry a one year parts and labor warranty. This warranty does not cover damages as a result of misuse, improper handling of the unit or exposure to extreme temperatures or moisture. At its discretion, ETS reserves the right to repair or replace this unit under the conditions of the warranty. If you experience problems with your equipment call ETS at: 505-888-3923 to obtain a return authorization number. Equipment requiring repair beyond the warranty period or units that have been damaged or are not covered under the warranty can be repaired by ETS for a minimal cost under most conditions.

Made in the USA
by
ETS Inc.

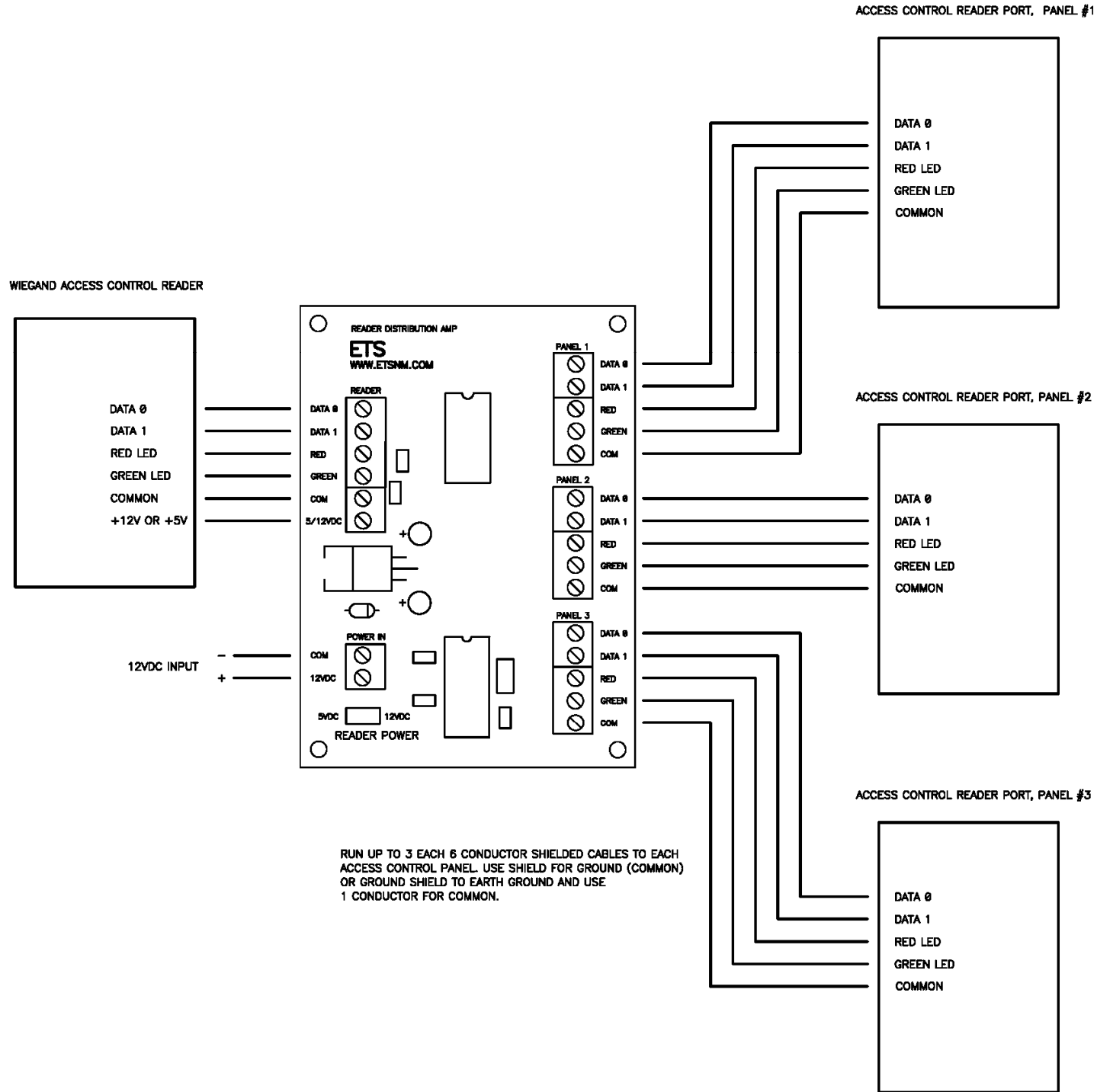

Figure 1.